

# NOVO

## Single-Cylinder Gasoline Engines

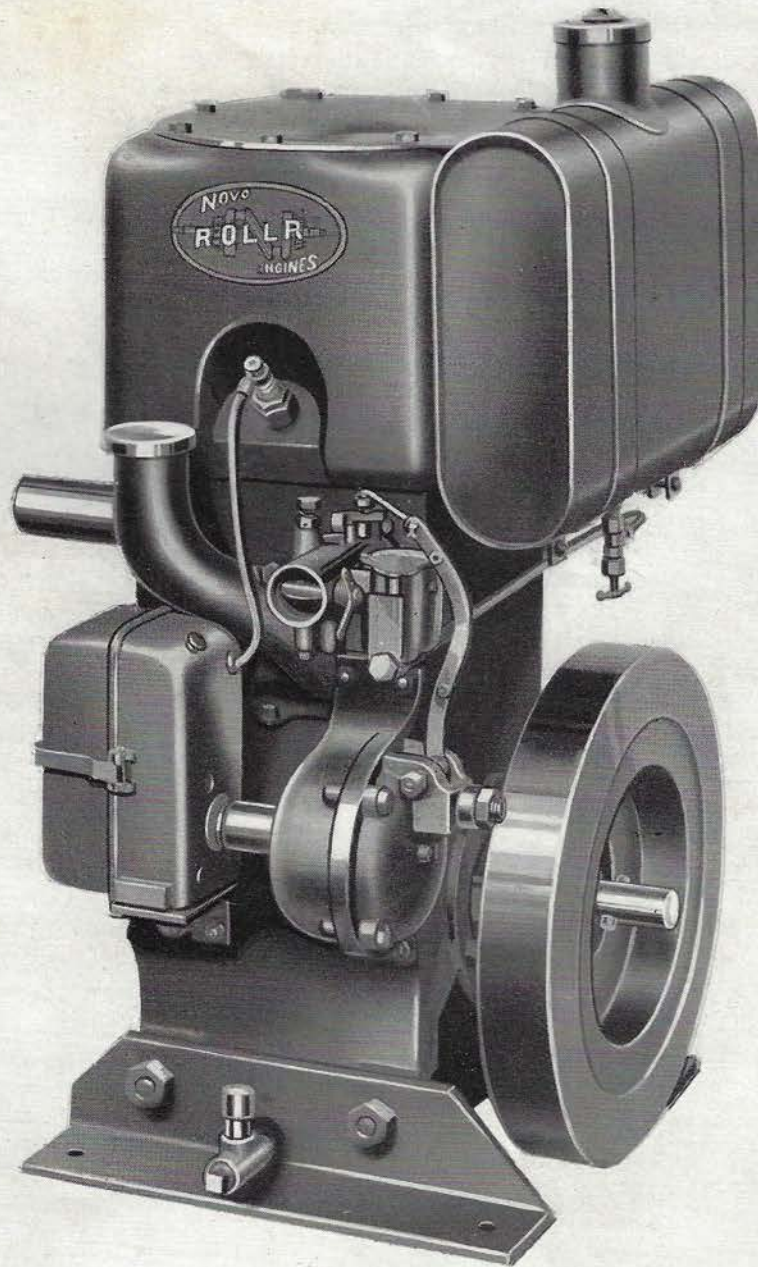

Novo Single-Cylinder, Hopper Cooled Engine

ENGINE SUPPLEMENT NO. 3

# S Single Cylinder Roller Bearing Power Units

## 3 TO 5 H. P. NOVO ENGINES

Novo Single-Cylinder Rollr Engines include the 3 H. P. Model KU and the 4 to 5 H. P. Model TU. These engines are hopper or radiator cooled and can be furnished with or without a lockable steel house. Standard crankshaft speed is 1200 R. P. M. Range or crankshaft speed 600 to 1800 R. P. M.

The Novo Single-Cylinder Rollr Engines are the vertical automotive type. They are L-head, four-cycle power units.

Timken Roller Bearings are used on the main crankshaft bearings, resulting in long life of the bearings without adjustment or replacement, less friction and simplified lubrication. All radial and thrust loads are amply cared for by these bearings.

### Chrome Nickel Blocks

The cylinder block, cast in our own foundry, contains a high percentage of steel and the proper percentage of chromium and nickel to give a close grained tough metal of high tensile strength that resists wear and withstands strain.

The cylinder is bored, reamed and honed. Cylinder is held to less than .001 of an inch tolerance.

### Counterbalanced Crankshaft

The precisely counterbalanced crankshaft assures a smooth flow of power regardless of speed. Each crank is tested for perfect balance.

### Gear Oiler

The Gear Oiled system of lubrication is used in all single-cylinder Rollr engines. Only one moving part, a small gear which is driven by the crankshaft pinion, picks up the oil from the crankcase and distributes it to all bearings, cams, gears, piston and connecting rod and other working parts within the crankcase—the simplest possible lubricating system—it can not fail regardless of temperature or condition of the oil.

### Automotive Type Carburetor

The single-cylinder Novo engines are equipped with a float feed, fixed high speed jet carburetor of the automotive type.

### High Tension Magneto

The high tension magneto gives a hot spark for easy starting and accurate timing for efficient operation. It is sealed, dust proof and moisture proof and requires no attention.

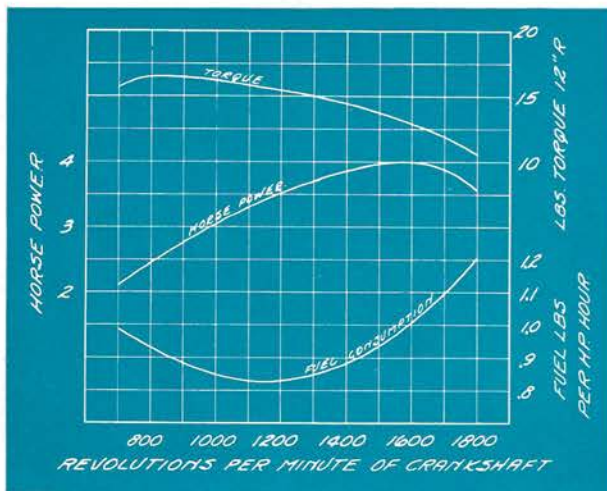

Performance curves of the KU 3 H. P. Engine. Rating is of a fully equipped engine—all accessories in operation

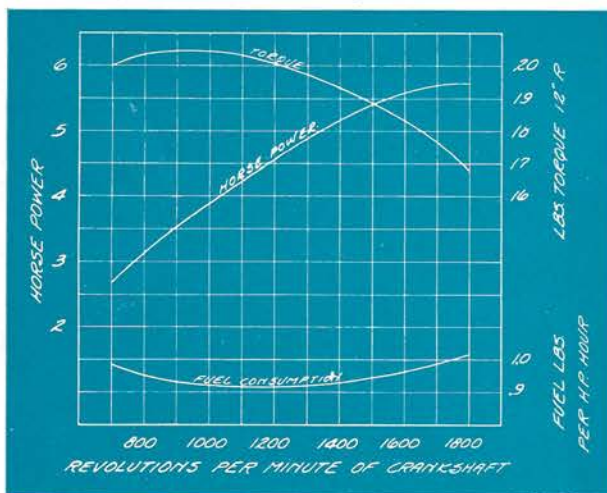

Performance curves of the TU 4-5 H. P. engine. Rating is made with fully equipped engine—all accessories in operation

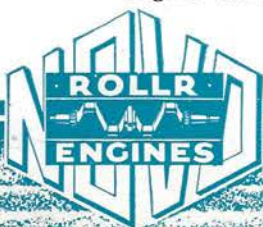

## Built-In Governor

A built-in, self-lubricating governor maintains a uniform speed at all loads within the engine's capacity. The governor is of the fly ball type. It requires no attention and proves a great saving on gasoline. As the load is released the governor keeps the engine throttled down to a uniform speed and prevents racing.

## Applications

Some industrial and agricultural applications of the Novo single-cylinder Rollr Engine are: Air compressors, concrete mixers, concrete surfacers, conveyors, electric generators, gas boosters, hoists, paint sprayers, pumps, road finishers, saw tables, ventilating fans, churns, corn shellers, cream separators, dust-ers, fruit sprayers, feed grinders, farm hoists, mowers, potato diggers, silage cutters, wood saws, etc.

## Drives Available

A variety of speed reductions are available with or without clutch and with either direction of rotation.

## SPECIFICATIONS

Model.....	KU	TU
Bore.....	3"	3 $\frac{3}{8}$ "
Stroke.....	4"	
R. P. M.....	1200	
Displacement.....	28.26 cu. in.	35.77 cu. in.
Fuel tank capacity.....	2 $\frac{3}{4}$ U. S. Gals.	
Oil capacity.....	3 pints	
Cooling.....	Hopper or radiator	
Valve diameter clear.....	1 $\frac{1}{16}$ "	
Connecting rod bearings.....	1 $\frac{1}{2}$ " dia. x 1 $\frac{1}{2}$ " long	
Main bearings—two.....	Timken roller bearings	
Timing gears.....	Spur—10 pitch, $\frac{3}{4}$ " face	
Piston.....	Special analysis cast iron	
Piston rings per piston.....	2 compression, 1 oil regulating	
Piston ring width.....	$\frac{1}{8}$ "	
Piston pin.....	$\frac{3}{4}$ " dia. (full floating type) hardened, ground and lapped	
Ignition.....	High tension rotating type magneto	
Crankshaft.....	1035 S. A. E. steel heat treated	
Cylinder block.....	Novite—Chrome nickel content alloy	
Carburetor.....	Float feed fixed high speed jet	
Fan diameter (Radiator cooled only).....	11"	
Flywheel diameter.....	13"	
Clutch.....	Own make	
*Approx. net weight, lbs.....	265	
*Approx. shipping weight, lbs.....	315	
Code, hopper cooled less house.....	NEKUR	NECTUB
Code, hopper cooled with house.....	NEFAN	NECUT
Code, radiator cooled with house.....	NEPAR	NEPID



Fig. 1542. Novo single-cylinder 3 to 5 H. P. Radiator Cooled Engine

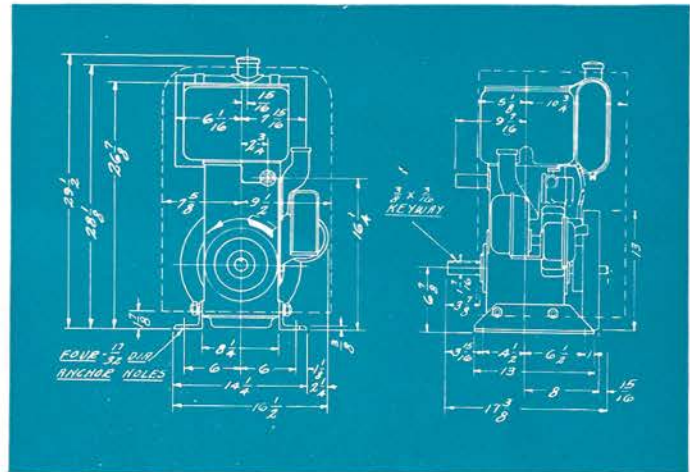

Dimensions of the 3-5 H. P. single-cylinder engine hopper cooled, crankshaft drive

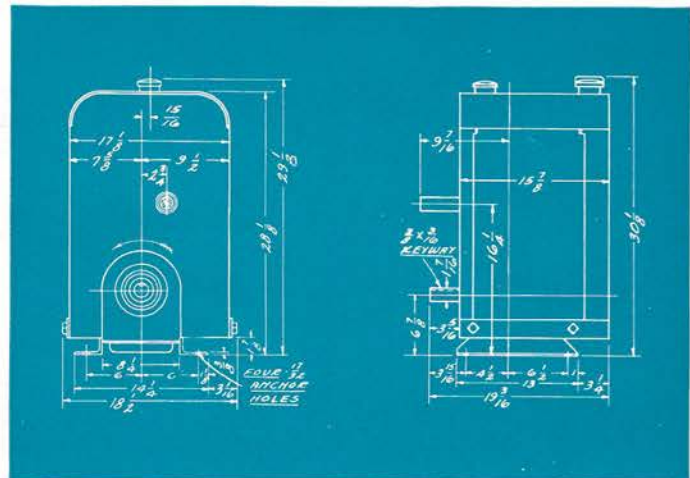

Dimensions of the single-cylinder radiator cooled engine with house, crankshaft drive.

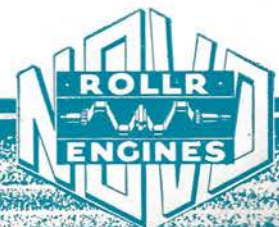

Features of  
Single Cylinder Engines  
3 to 5 H. P.

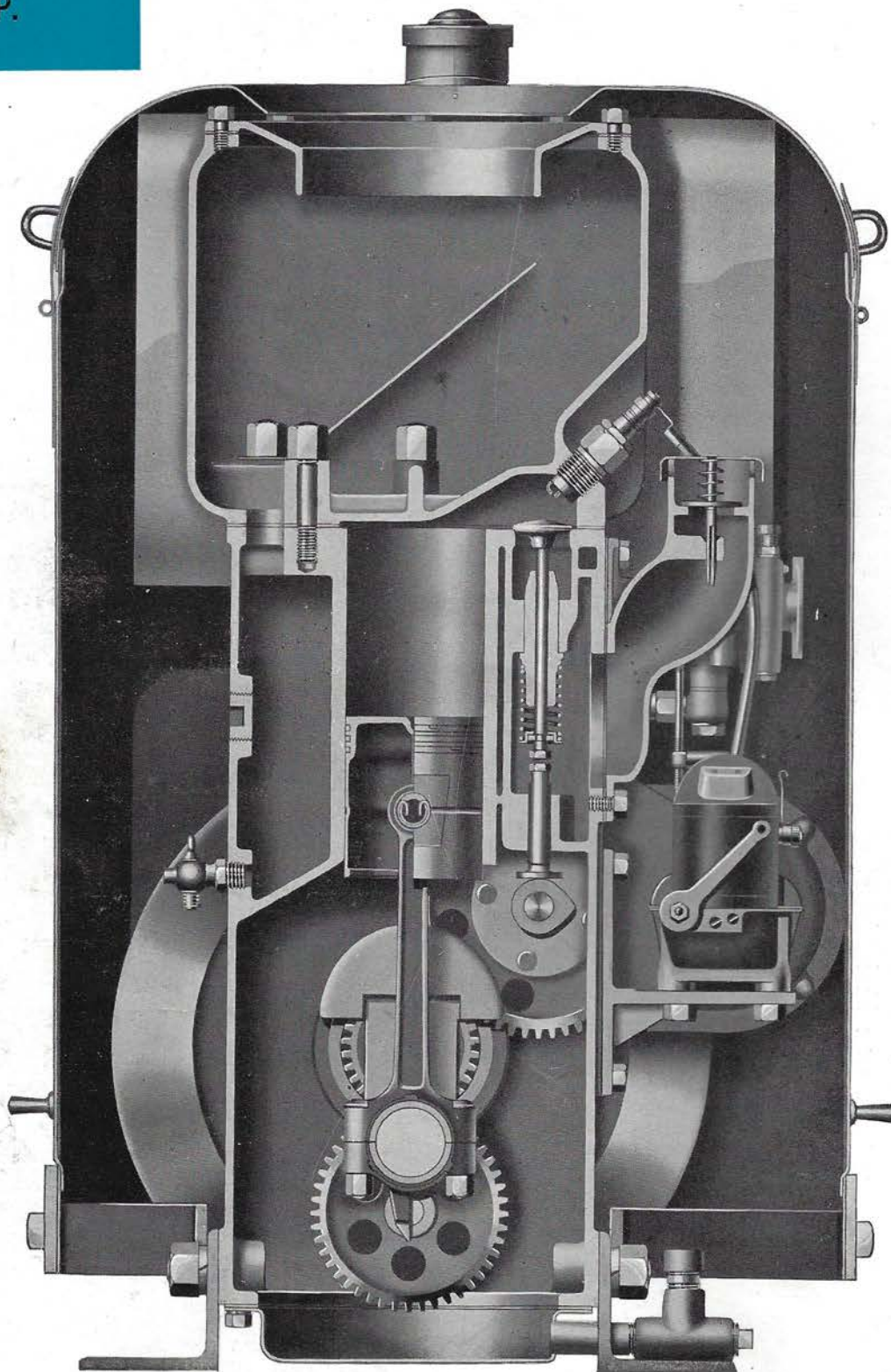
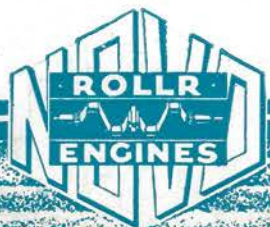

Fig. 1479. Transverse cross-section of the single-cylinder hopper cooled Rollr Engines—3-5 H. P. Note the large water jacket space, modern combustion chamber design and the simplified gear oiling system.



**NOVO ENGINE CO.**  
LANSING, MICHIGAN, U. S. A.